

**canadair**  
**Challenger**  
WIRING MANUAL  
PSP 601-3A

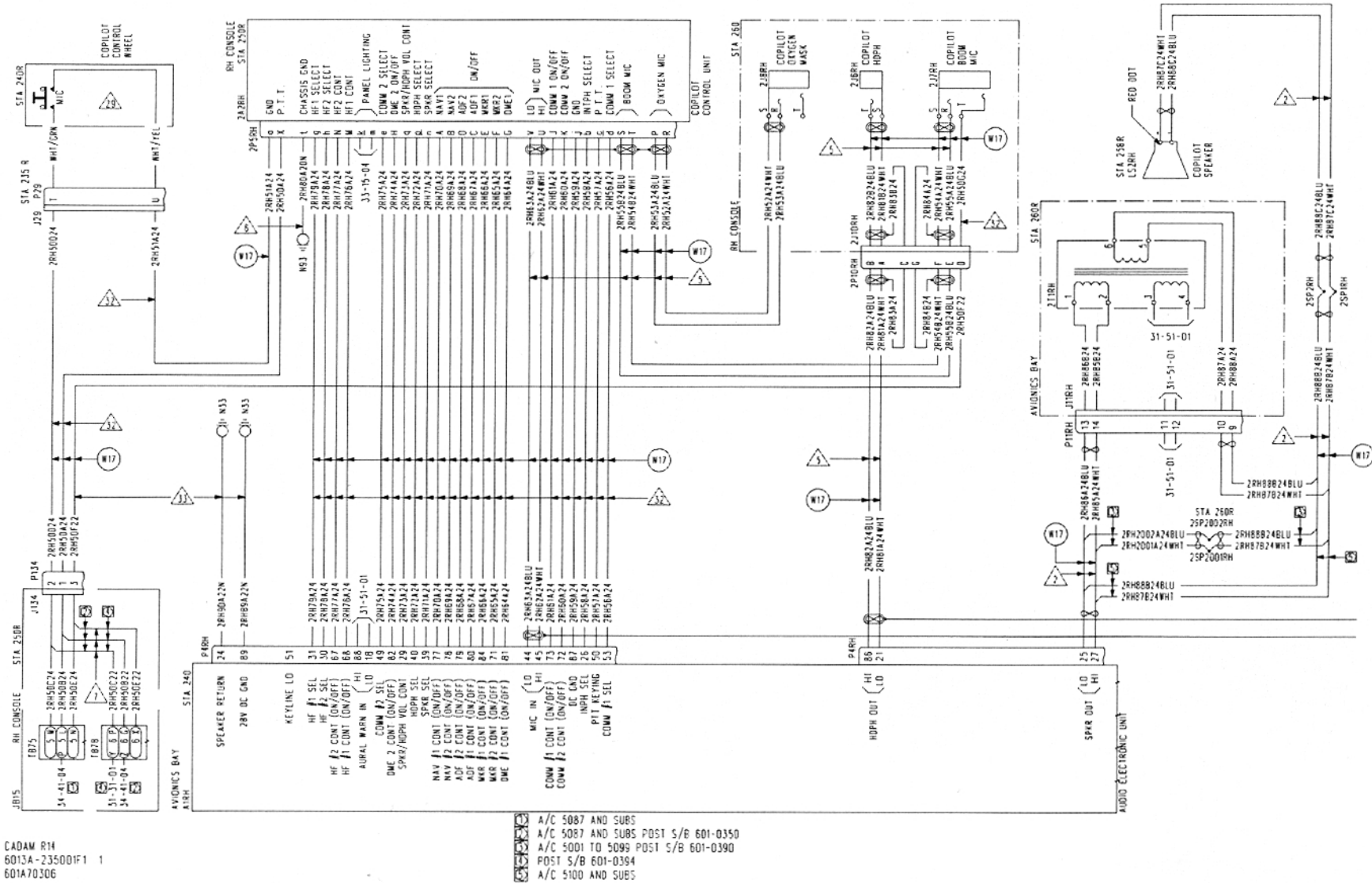

CADAM R1H  
6013A-235001F1 1  
601A70306

INTERCOM SYSTEM  
(DOT, FAA AND CAA CERTIFIED A/C)  
FIGURE 1 (SHEET 1)

**canadair**  
**challenger**  
**WIRING MANUAL**  
**PSP 601-3A**

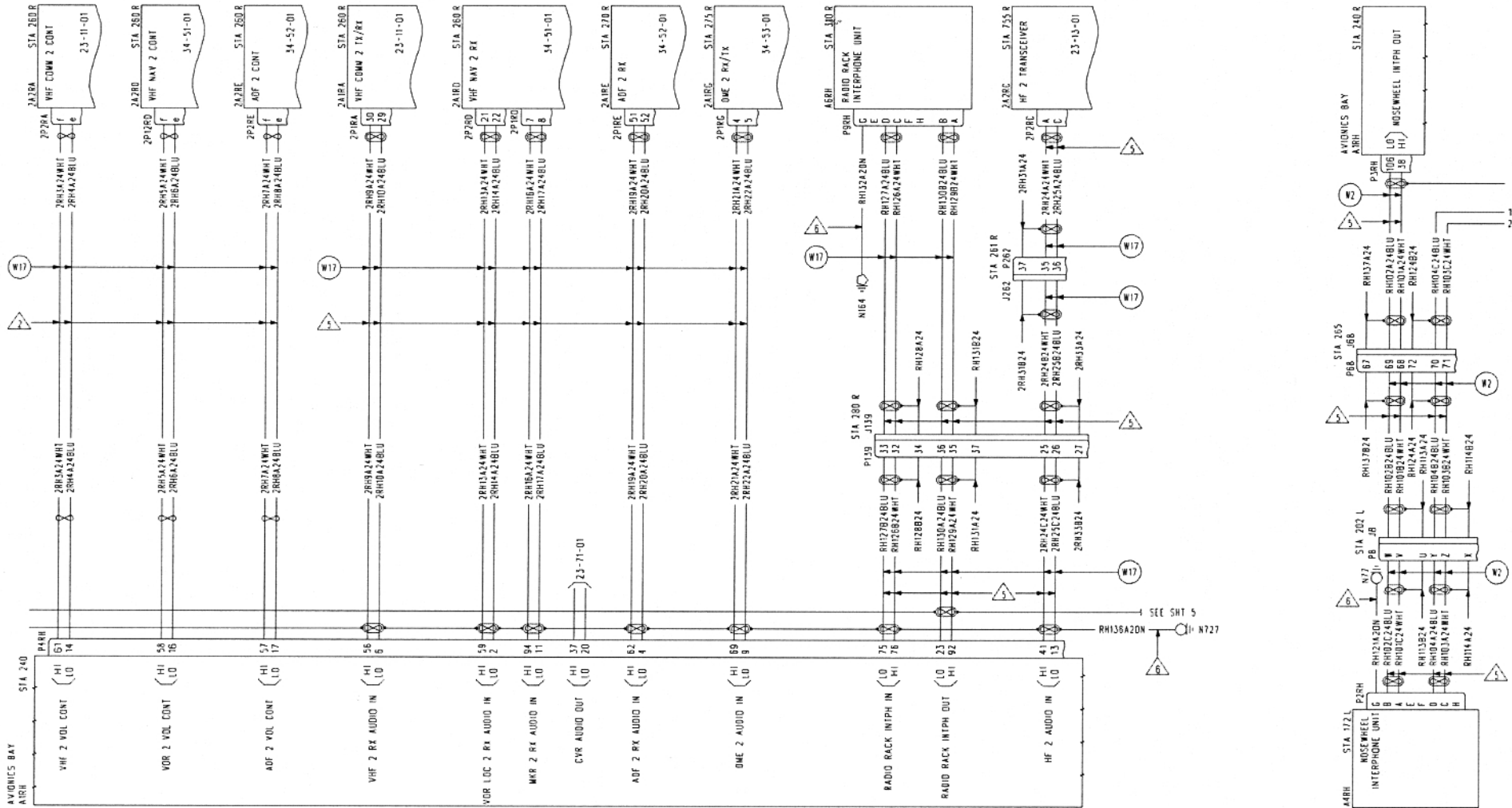

CADAM R10  
6013A-23500F1 2  
601A-70306

INTERCOM SYSTEM  
(DOT, FAA AND CAA CERTIFIED A/C)  
FIGURE 1 (SHEET 2)

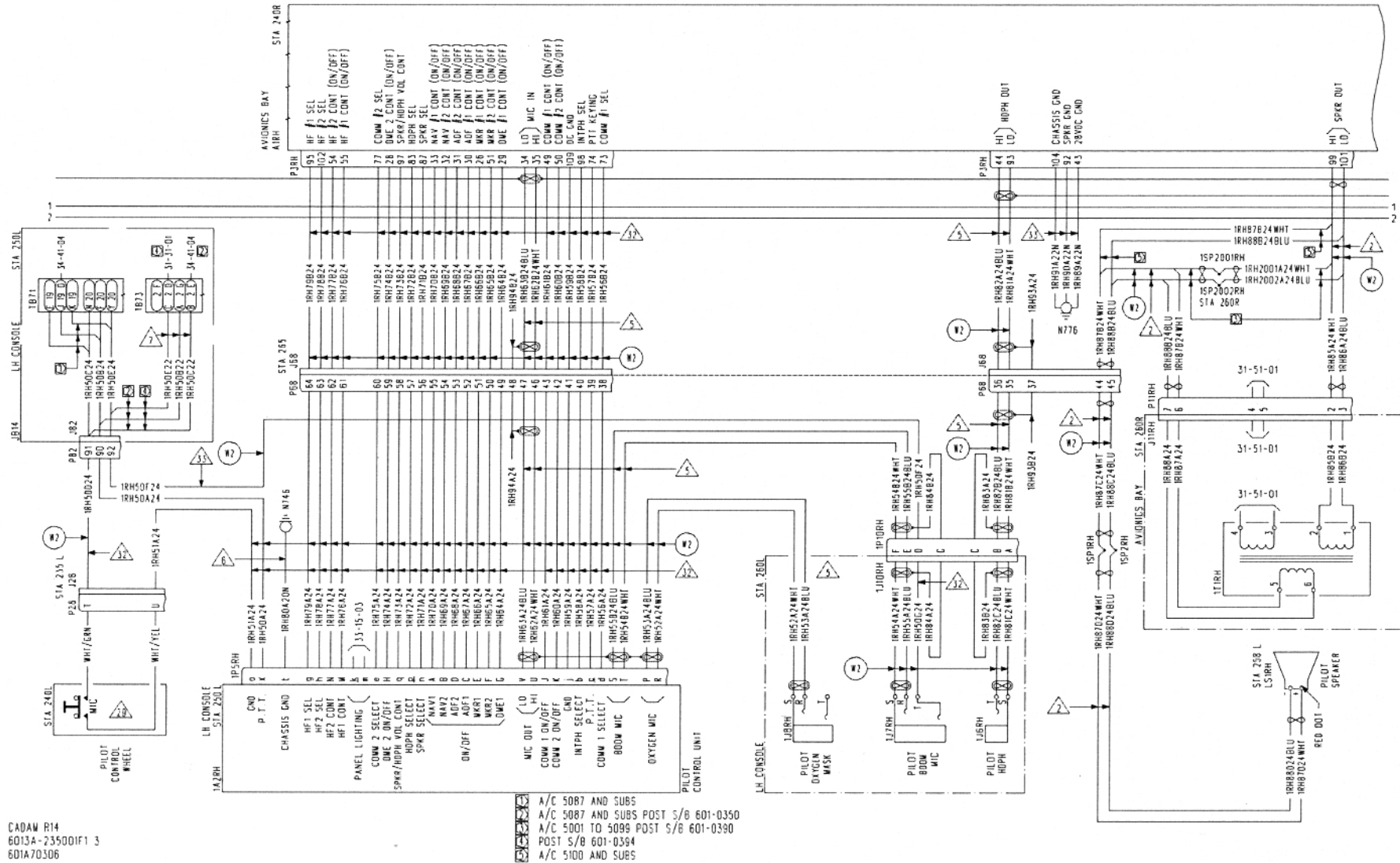

CADAW R14  
6013A-235001F1 3  
601A70306

**INTERCOM SYSTEM**  
(DOT, FAA AND CAA CERTIFIED A/C)  
**FIGURE 1 (SHEET 3)**

**canadair  
Challenger**  
WIRING MANUAL  
PSP 601-3A

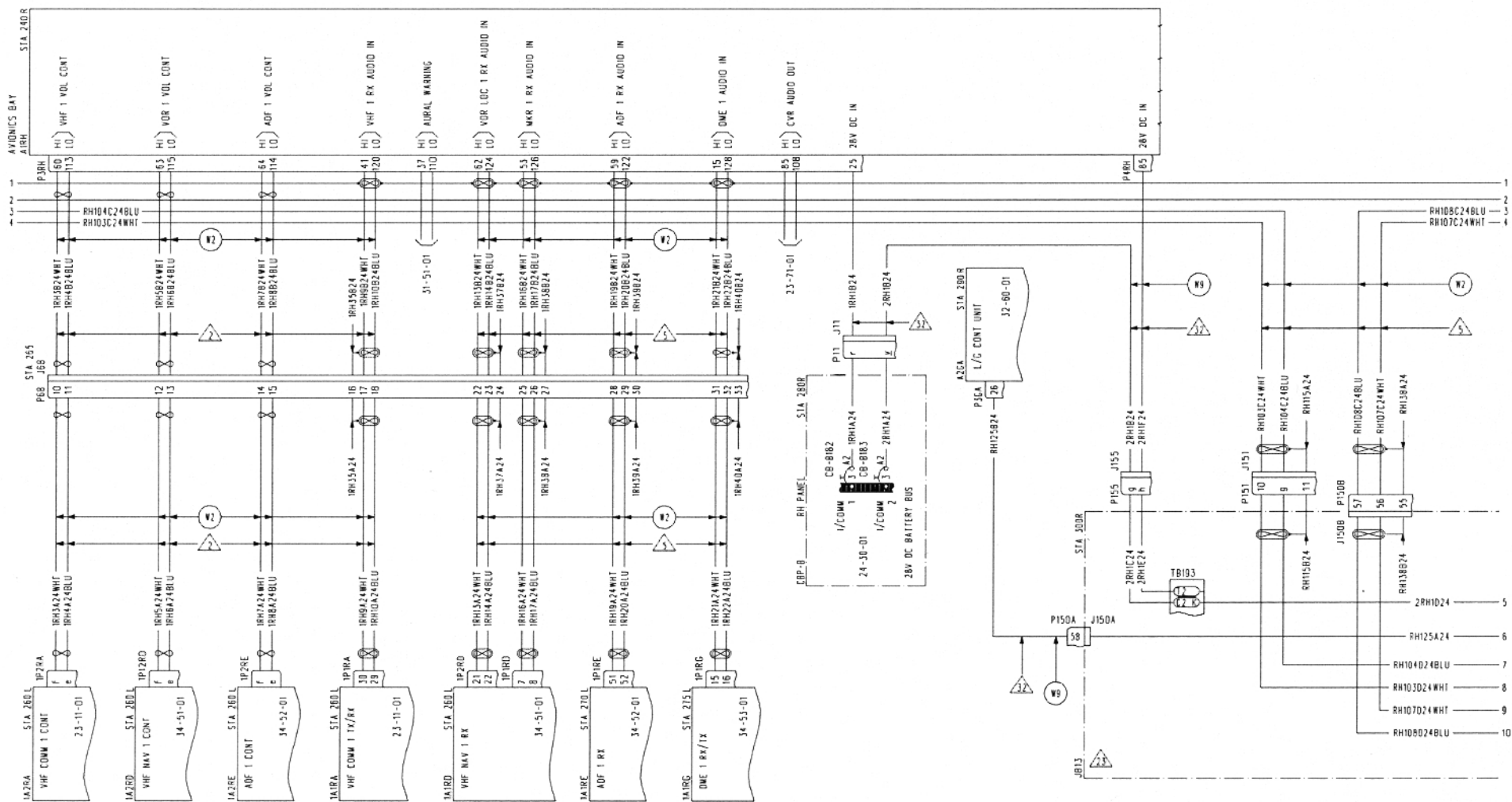

CADAM R7  
6013A-23500F1 4  
601A-70506

INTERCOM SYSTEM  
(DOT, FAA AND CAA CERTIFIED A/C)  
FIGURE 1 (SHEET 4)

**canadair**  
**challenger**  
**WIRING MANUAL**  
**PSP 601-3A**

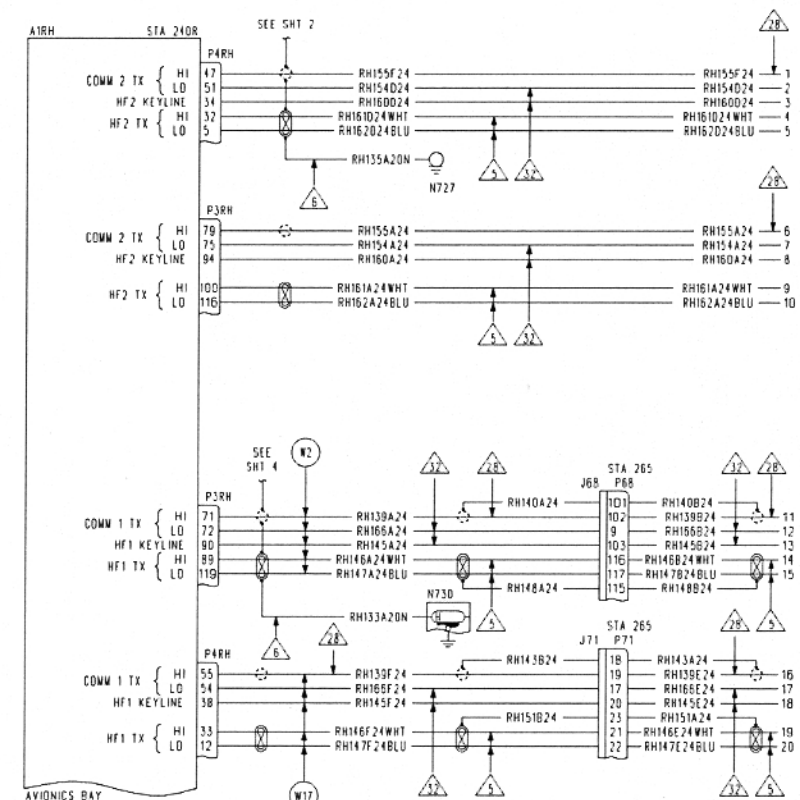
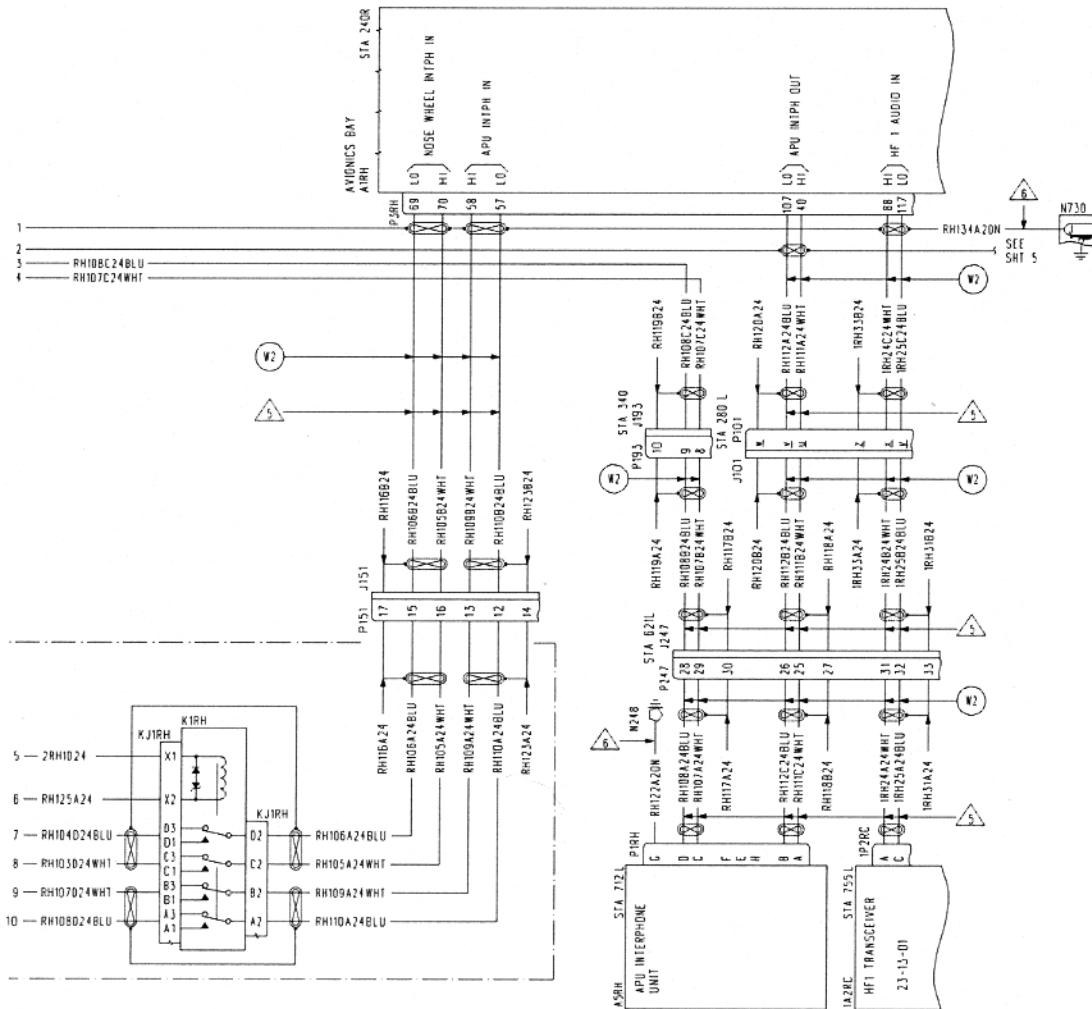

CADAM R7  
6013A-235001F1 5  
601A-70306

**INTERCOM SYSTEM**  
**(DOT, FAA AND CAA CERTIFIED A/C)**  
**FIGURE 1 (SHEET 5)**

**canadair  
challenger**  
WIRING MANUAL  
PSP 601-3A

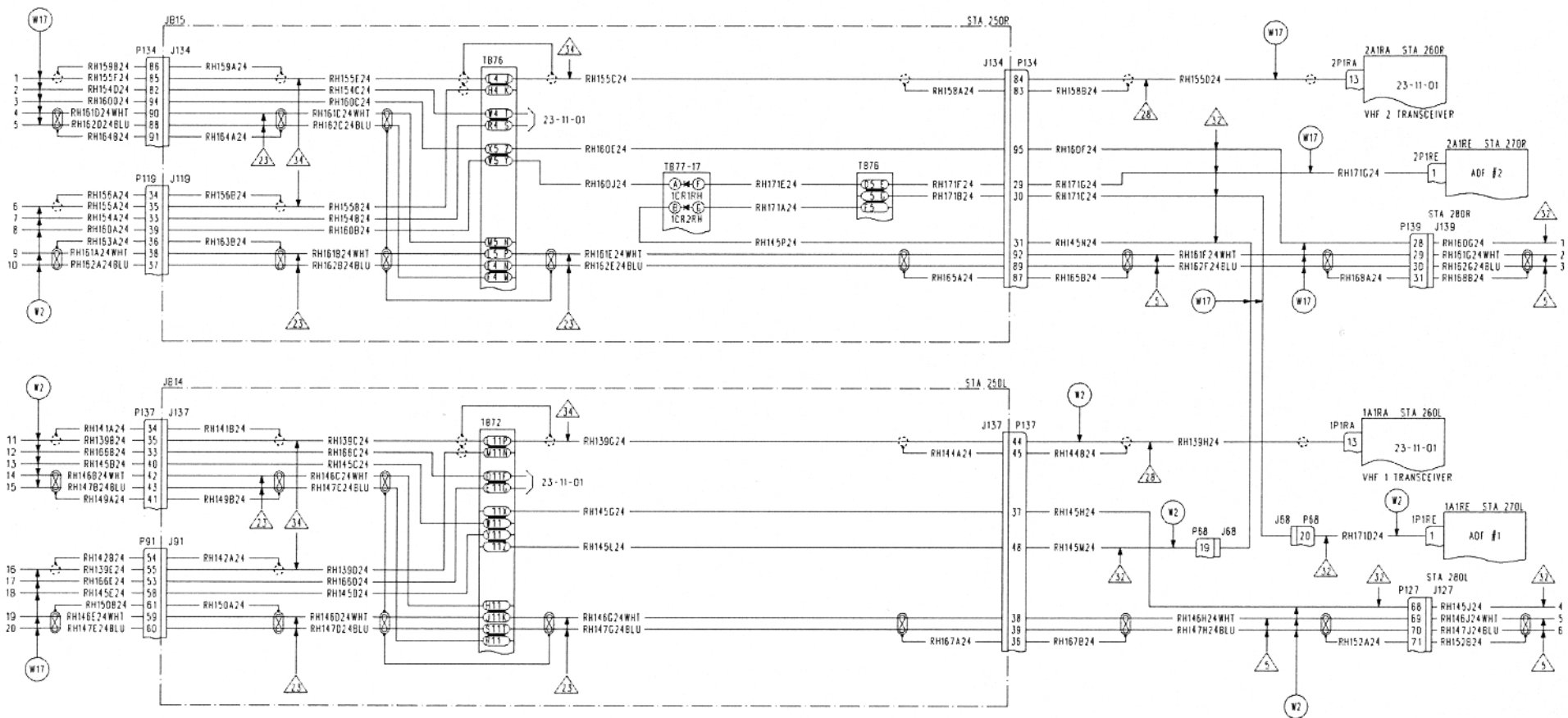

CADAM R9  
6013A-235001F1 6  
601A-70306

INTERCOM SYSTEM  
(DOT, FAA AND CAA CERTIFIED A/C)  
FIGURE 1 (SHEET 6)

**23-50-01**  
Page 11/12  
Apr 12/91

**canadair  
challenger**  
WIRING MANUAL  
PSP 601-3A

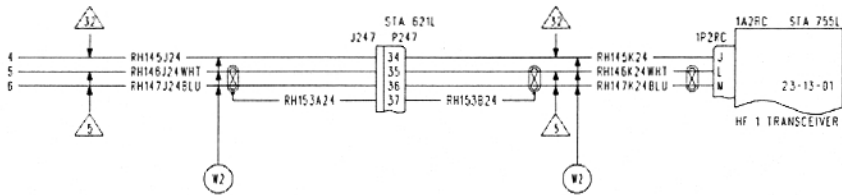
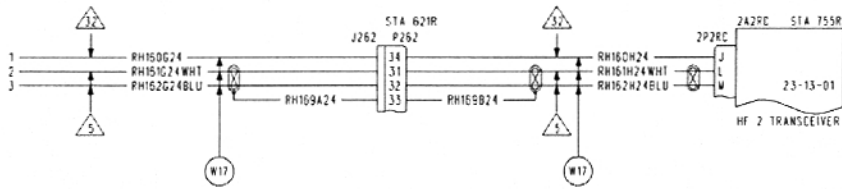

CADAW R7  
6013A-235001F1 7  
601A-70306

INTERCOM SYSTEM  
(DOT, FAA AND CAA CERTIFIED A/C)  
FIGURE 1 (SHEET 7)

**23-50-01**  
Page 13/14  
May 31/90

△1 CABLE TO BE M27500-245C1123.

△2 WIRE TO BE M81381/22-22-9.

△3 WIRE TO BE M81381/13-24-9.

31 ALL UNIDENTIFIED SHIELD JUMPER WIRES TO BE M22759/35-24-9.

△4 PART NUMBER 600-90101.

△5 CABLE TO BE M27500-24WT1522.

△6 CABLE TO BE M27500-245C2123.

△7 WIRE TO BE M22759/34-22-9.

△8 WIRE TO BE M81381/22-20-9.

△9 CABLE TO BE M27500-24WT2522.

3 UNLESS OTHERWISE SPECIFIED ALL WIRES TO BE M22759/35-24-9.

△10 CABLE TO BE M27500-24NA2000.

1 UNLESS OTHERWISE SPECIFIED ALL WIRES TO BE CODE W7.

NOTES:

S/B 601-0350, -0390 AND -0394 INCORPORATED.

KIT DWGS K600-52008A, K601A51019B, AND K601A53002B INCORPORATED.

CANADAIR DWG 601A7066INC4 INCORPORATED.

CADAM R14  
6013A-23500F1 8  
601A70306C